

AR1.2 MINI TM USER MANUAL

Battery System
12.8V/100Ah

Content

- 1 PRODUCT PARAMETER..... 1
- 2 USAGE INSTRUCTIONS 2
- 3 CHARGING INSTRUCTIONS 3
 - Solar Panel and controller..... 3
 - Battery Charger 4
 - Alternator/Generator..... 5
- 4 RECOMMENDED CABLE SIZING..... 6
- 5 SERIES/PARALLEL CONNECTION INSTRUCTIONS..... 6
 - Precautions before connection..... 6
 - Maximum number of series-parallel connections..... 6
 - Voltage balancing before connection..... 7
 - How to connect batteries 7
 - Rebalancing every 6 months..... 9
- 6 FAQ's 10
- 7 PRECAUTIONS 11

1 PRODUCT PARAMETER

Table 1-1

Num.	Item	Parameter
1.1	Nominal Voltage	12.8V
1.2	Rated Capacity	100Ah
1.3	Energy	1280Wh
1.4	Charge Method	CC/CV
1.5	Charge Voltage	14.4V±0.2V
1.6	Recommended Charge Current	20A(0.2C)
1.7	Max. Continuous Charge Current	100A
1.8	Max. Continuous Discharge Current	100A
1.9	Max. Continuous Output Power	1280W
1.10	Terminal Bolts	M8 ×16mm
1.11	Recommended Terminal Torque	88.5~106.2 lbs·in / 10~12 N·M
1.12	Housing Material	Black (ABS)
1.13	Dimensions	L259×W168×H209 mm
		L10.23×W6.61×H8.22 inch
1.14	Temperature Range	Charge:0°C~50°C/32°F~122°F
		Discharge:-20°C~55°C/-4°F~131°F
		Storage:0°C~60°C/32°F~140°F
1.15	Charging Protection Temperature	0°C/32°F
1.16	Resume Charging Temperature	5°C/41°F
1.17	Protection Class	IP65

2 USAGE INSTRUCTIONS

- When the product is first unpacked, verify that it is working properly.
- When using the battery, be careful to avoid metal or conductive objects touching the positive and negative poles of the battery at the same time, otherwise it may cause a short circuit.
- Tightly screw in the post bolts. Having loose battery terminals will cause the terminals to build up heat resulting in damage to the battery.
- DO NOT use it as a starting battery.
- For a longer-lasting product, it is best to store your battery at a 50% charge level and recharge every six months if it is not going to be used for a long time.
- The battery capacity could be roughly estimated by its resting voltage, resting voltage is the battery has been disconnected from the charger and loads with zero current, and left alone for 3 hours. Table 2-1 shows the approximate correspondence between voltage and the range of SOC.

Table 2-1

Voltage (V)	SOC (%)
<10.8V	0%
10.8V~12.9V	1%~20%
12.9V~13.0V	20%~30%
13.0V~13.2V	30%~70%
13.2V~13.3V	70%~95%
13.3V~14.0V	95%~100%

3 CHARGING INSTRUCTIONS

Solar panel and controller

- **How to choose solar panels :**

It is recommended that the solar panel (PV) is in the range of $\geq 400W$ (if the solar panel is $400W$, its efficiency is about 80%, and the effective light time is 4.5h, it can be fully charged in one day).

- **How to set the controller :**

Please select the appropriate charging current according to the requirements, Recommended charging current is $20A(0.2C)$, The battery will be fully charged in around 5hrs; Please choose $12V(14.6V)$ Li (LiFePO4) mode;

Refer to the below parameters if you need to manually set up your controller:

Table 3-1

Charging settings		Discharging settings	
Charge Voltage	14.4±0.2V	Under Voltage Warning	11.6V
Absorption Voltage	14.4±0.2V	Under Voltage Recover	12.4V
Over Voltage Protect	15.0V	Low Voltage Protect	10.8V
Over Voltage Reconnect	14.0V	Low Voltage Reconnect	12.0V
Tail Current	5A(0.05C)	/	

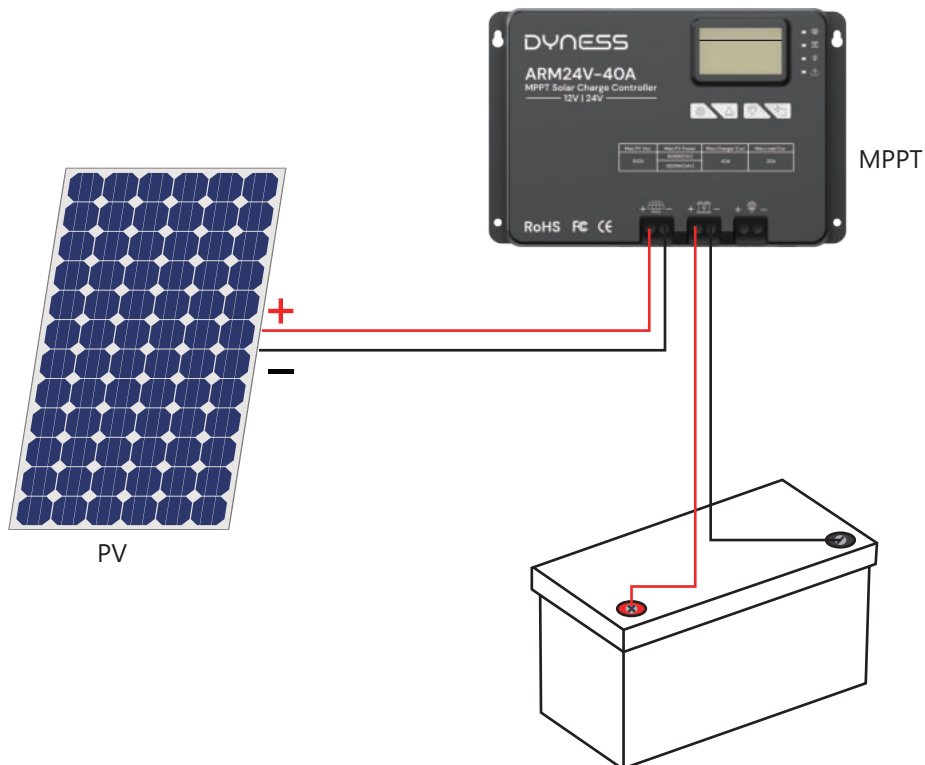

Figure 3-1

Battery charger

- Use 14.6V lithium iron phosphate (LiFePO₄) battery charger to maximize the capacity.
- Please select the appropriate charging current according to the requirements, Recommended charging current is 20A(0.2C), The battery will be fully charged in around 5hrs;
- It is not recommended to use alligator clips to connect the charger or load to the battery as the contact area is too small and can cause the terminals to melt and damage the battery;

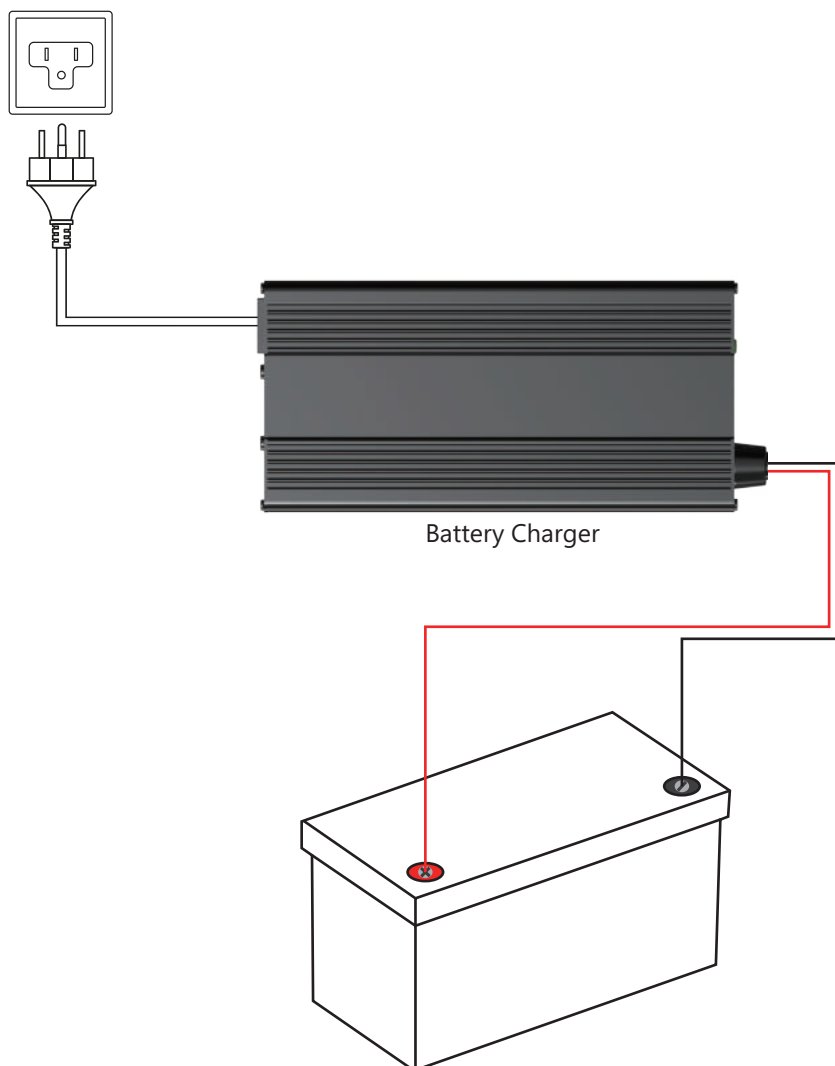

Figure 3-2

Alternator/Generator

- Dyness battery can be charged by an alternator or generator.
- Confirm the alternator/generator supports AC output, please refer to the recommendations in "Battery Charger" above to add a suitable battery charger between the battery and the generator.
- Recommended Charging Voltage: Between 14.2V to 14.6V.

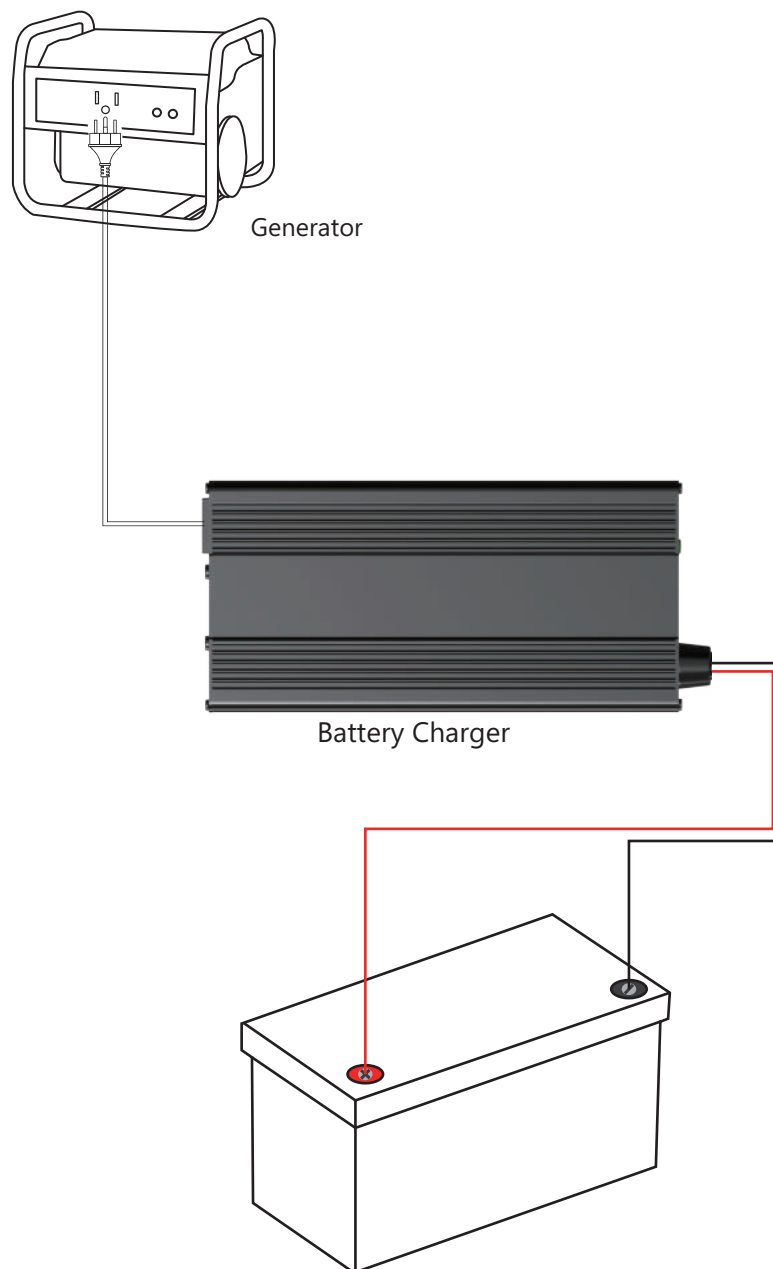

Figure 3-3

4 RECOMMENDED CABLE SIZING

Battery cables should be properly sized to handle the expected load. Refer to the table below for amperage ratings for different sizes of copper cables. The values are from NEC Table 310.15(B)16.

PVC COPPER CABLE SIZE(AWG/mm ²)	AMPACITY(A)
14(2.08)	20
12(3.31)	25
10(5.25)	35
8(8.36)	50
6(13.3)	65
4(21.1)	85
2(33.6)	115
1(42.4)	130
1/0(53.5)	150
2/0(67.4)	175
4/0(107)	230

Figure 4-1

5 SERIES/PARALLEL CONNECTION INSTRUCTIONS

Precautions before connection:

- Identical batteries with the same battery capacity(Ah) and BMS(A)
- from the same brand.
- purchased in near time(within six month)
- Wear insulating gloves for protection before connecting. Please pay attention to operation safety in the process of connection.

Maximum number of series-parallel connections

Support connecting up to 16 identical batteries for up to:

- 4 in series as **51.2V 100Ah** battery system.
- 4 in parallel as **12.8V 400Ah** battery system.
- 16 in series and parallel as **51.2V 400Ah** battery system.

Voltage Balancing Before Connection

Below two steps are necessary to reduce the voltage difference between batteries and let the battery system perform the best of it in series or/and in parallel.

- Fully charge the batteries separately, insure batteries voltage at rest: $\geq 13.35V$;
- Connect all of the batteries in parallel, and leave them together for 12~24hrs;

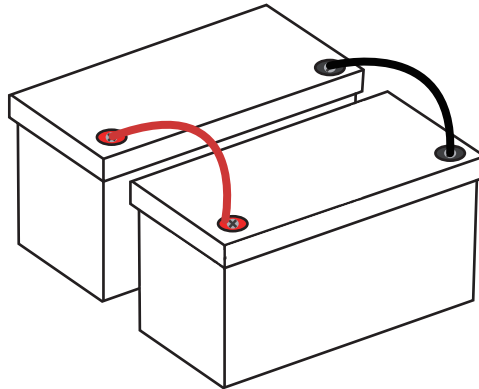

How To Connect Batteries

- Connect Batteries in Series: After series connection, the voltage of the battery system will be doubled according to the number of batteries you connect.

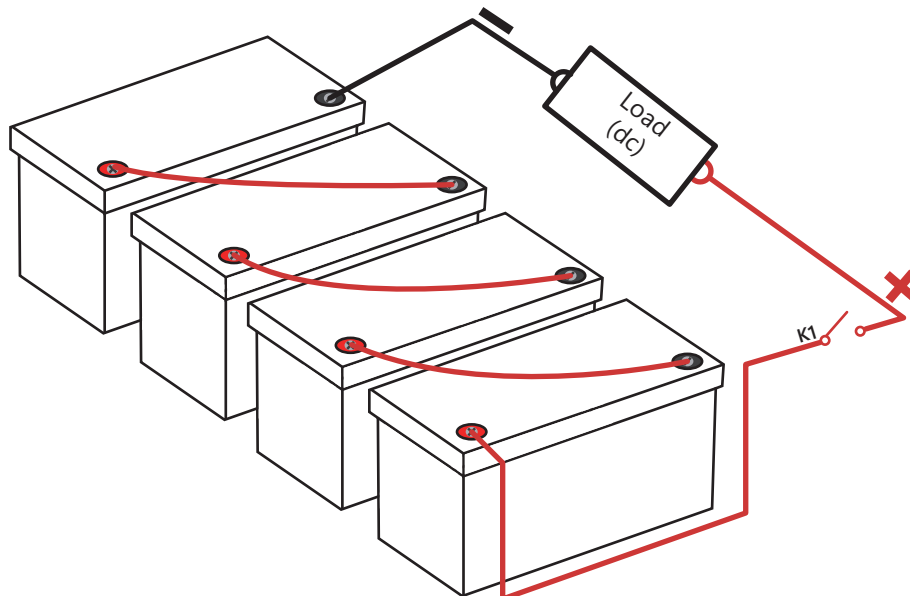

Figure 5-1 Series Application: 4S1P, 51.2V 100Ah

- Connect Batteries in Parallel: After parallel connection, the capacity of the battery system will be doubled according to the number of batteries you connect.

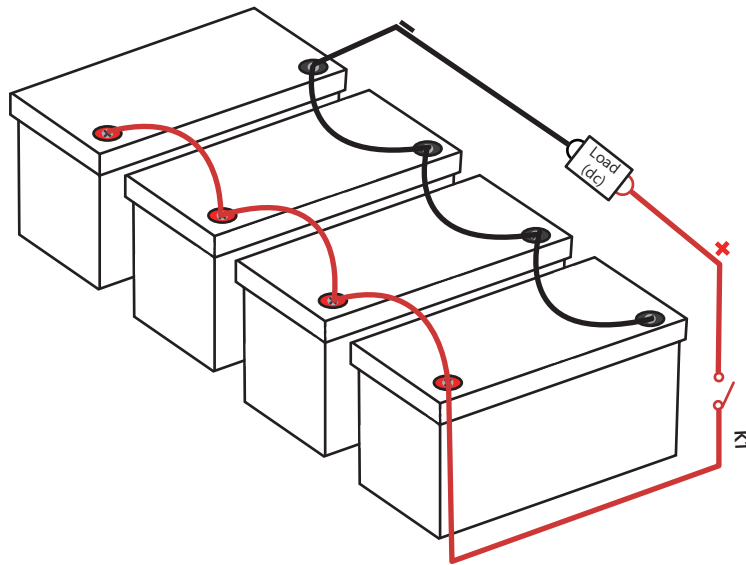

Figure 5-2 Parallel Application: 1S4P,12.8V 400Ah

- Connect Batteries Both in Series & Parallel: Connect in parallel first, then series.

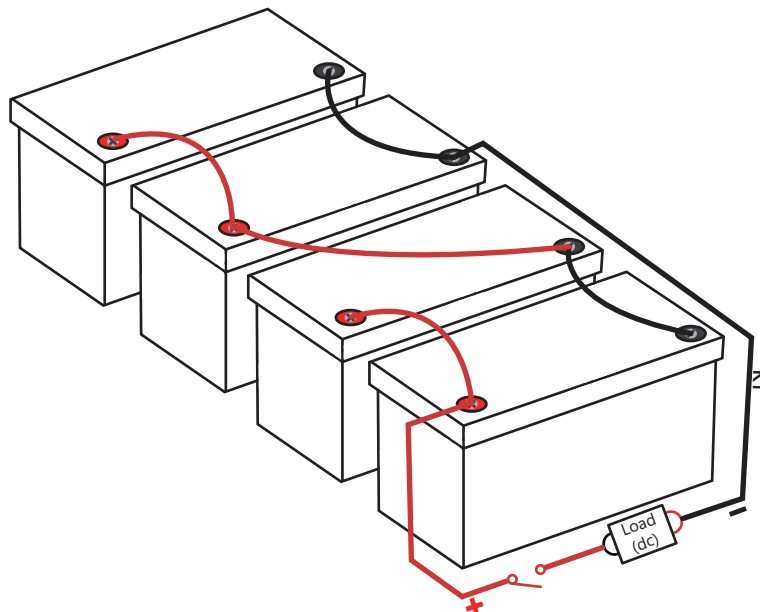

Figure 5-3 Series-parallel Applications: 2S2P,25.6V 200Ah

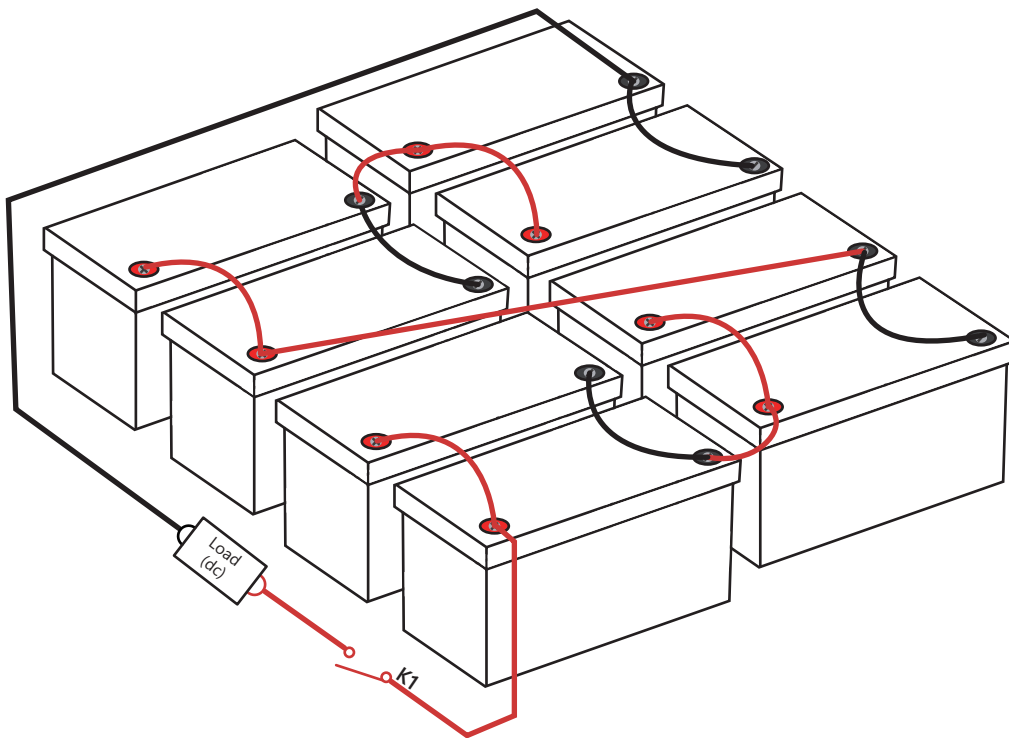

Figure 5-4 Series-parallel Applications: 4S2P,51.2V 200Ah

Rebalancing every 6 months

It is recommended to rebalance the battery voltage every six months following Voltage Balancing if you're connecting multiple batteries as a battery system, as there might be voltage differences after six months of the battery system running.

6 FAQ's

When the battery "Can't work" or "Can't be charged" or "Voltage<9V", It has 90% chances that BMS has shut it off for protection, and you could try one of below ways to activate the battery.

Method 1: Cut off all the connections from the battery, Leave the battery aside for 30mins. Then the battery will automatically recover itself to normal voltage (>10V) and can be used after fully charged.

Method 2: Use a 0V charger to charge the battery until the charging voltage is between 14V and 14.6V.

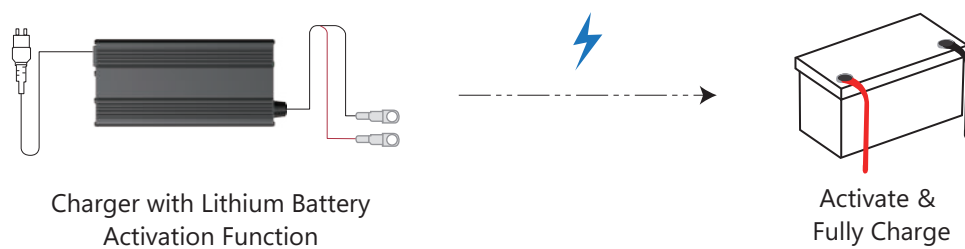

Figure 6-1

Method 3: Connect solar panel, and solar controller (MPPT) required, charging **3~10 seconds** under sunny conditions.

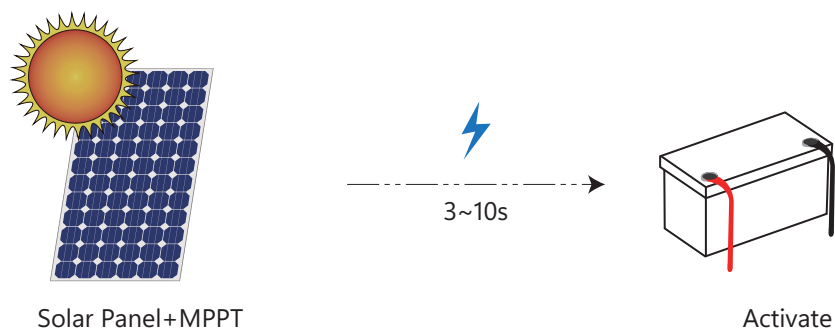

Figure 6-2

7 PRECAUTIONS

- To register your battery warranty, please contact us at dynesscare@dyness-tech.com after receiving your batteries.
- When using this product, please strictly follow this user manual.
- It is strictly prohibited to reverse the positive and negative poles of the battery.
- Please use a professional lithium battery charger.
- Please do not use unofficial parts.
- Please stop using the battery if it smells, changes color, makes noise, leaks, or is severely deformed.
- Size the Battery Cables and Connectors Appropriately. Use high-stranded copper connectors and heavy gauge cables to handle possible battery loads. Make sure to keep identical cable lengths. Avoid accidents caused by unsuitable connectors or cables that make the connection a heat source during battery operation.
- Please tighten all cable connections, as loose cable connections can cause terminal meltdown or fire.
- It is strictly forbidden to place this product close to heat sources, such as fire sources or heating furnaces. Excessive temperature may cause the battery to catch fire or even explode. If the product catches fire, use water or water mist, sand, fire blanket, dry powder, or carbon dioxide fire extinguisher to extinguish the fire.
- It should be safely secured to a solid plane and the cables safely tied to a suitable location to avoid arcing and sparking due to friction.
- It is strictly prohibited to immerse this product in water and do not use this product in the rain. If the product accidentally falls into the water during use, please place it in a safe open area and stay away from the product until the product is completely dry; the dried product must not be used again and should be properly disposed of according to the discard method.
- It is strictly prohibited to dismantle the product without permission or puncture it with sharp objects; it is prohibited to use wires or other metal objects to cause short circuit of the product.
- It is prohibited to stack heavy objects on this product.
- It is prohibited to use the product in an environment with strong static electricity or strong magnetic field.
- Avoid impacts, drops, and violent vibrations. If there is a serious external impact, please stop using it immediately.
- Avoid long-term sunlight exposure. It is recommended to use or store this product in an environment of 15°C to 35°C.
- Please secure it during transportation.
- Please store this product out of the reach of children and pets.
- When products need to be scrapped, they must be scrapped in accordance with local laws and regulations.

DYNNESS

Address: No. 511 Chenzhuang West Road, Sanshui Street,
Jiangyan District, Taizhou City

Email: dynesscare@dyness-tech.com

Tel: +86 400 666 0655

Web: www.dynesspower.com



Official Website



Digital version access